

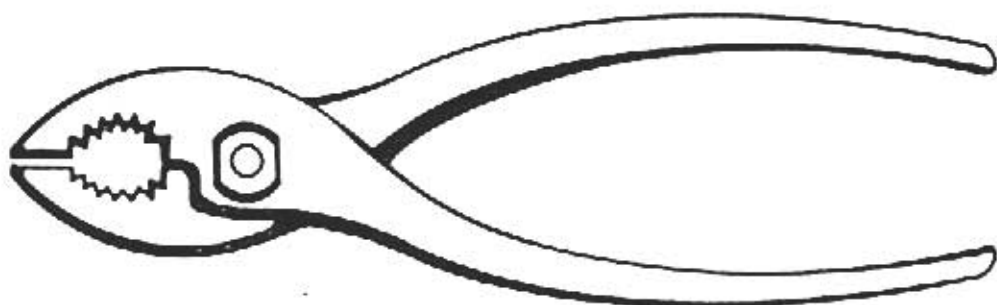

HG-3-1110



SAMUEL JACKSON MANUFACTURING CORP.

LUBBOCK, TEXAS 79490

DIMENSIONS

TEMPERATURE CONTROL ASSEMBLY

<u>PART NO.</u>	<u>FOR MODEL NO.</u>
14070	HG-3-1110, HG-6-1111
14070A	HG-3-1110A, HG-6-1111A
14610	HO-4-1112



TOP VIEW

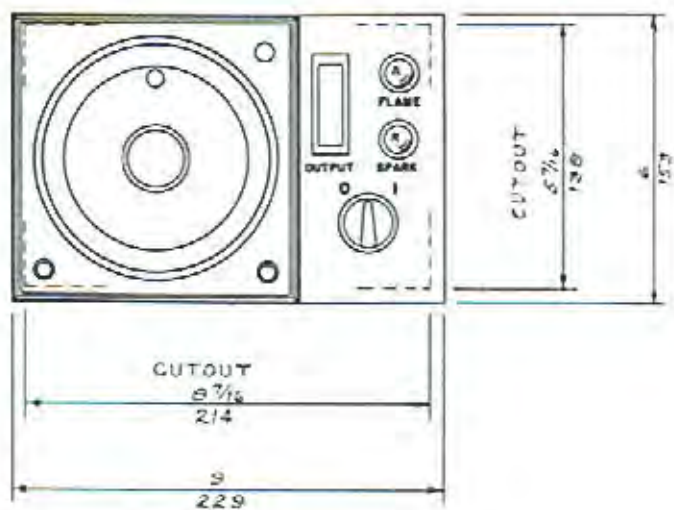

INLET AND OUTLET FLANGES
 IDENTICAL. CONNECTION CAN
 BE 30" ID CIRCULAR FLANGE,
 1-1/2" WIDE WITH 16 HOLES
 (3/8" Ø) EQUALLY SPACED ON
 31-1/2" DIAMETER CIRCLE.

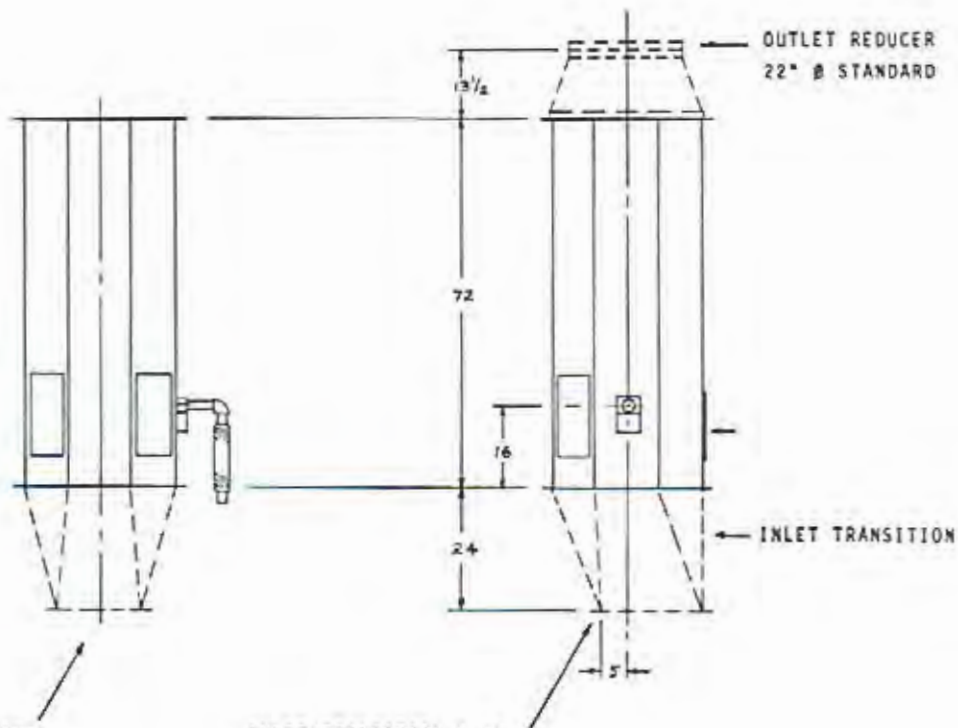
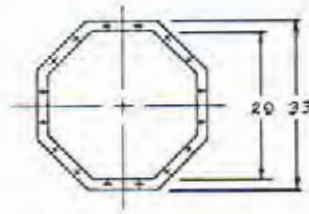

RECTANGULAR OPENING
 TO FIT FAN DISCHARGE

INLET TRANSITION MUST
 BE INSTALLED ON FAN
 OUTLET SO FAN SCROLL
 IS AT THIS EDGE.
 BURNER MAY BE ROTATED
 TO ANY POSITION WITH
 RESPECT TO TRANSITION.

EXTERNAL ELECTRICAL CONNECTIONS

HG-3-1110A

3 MBTU/HR GAS-FIRED HEATER

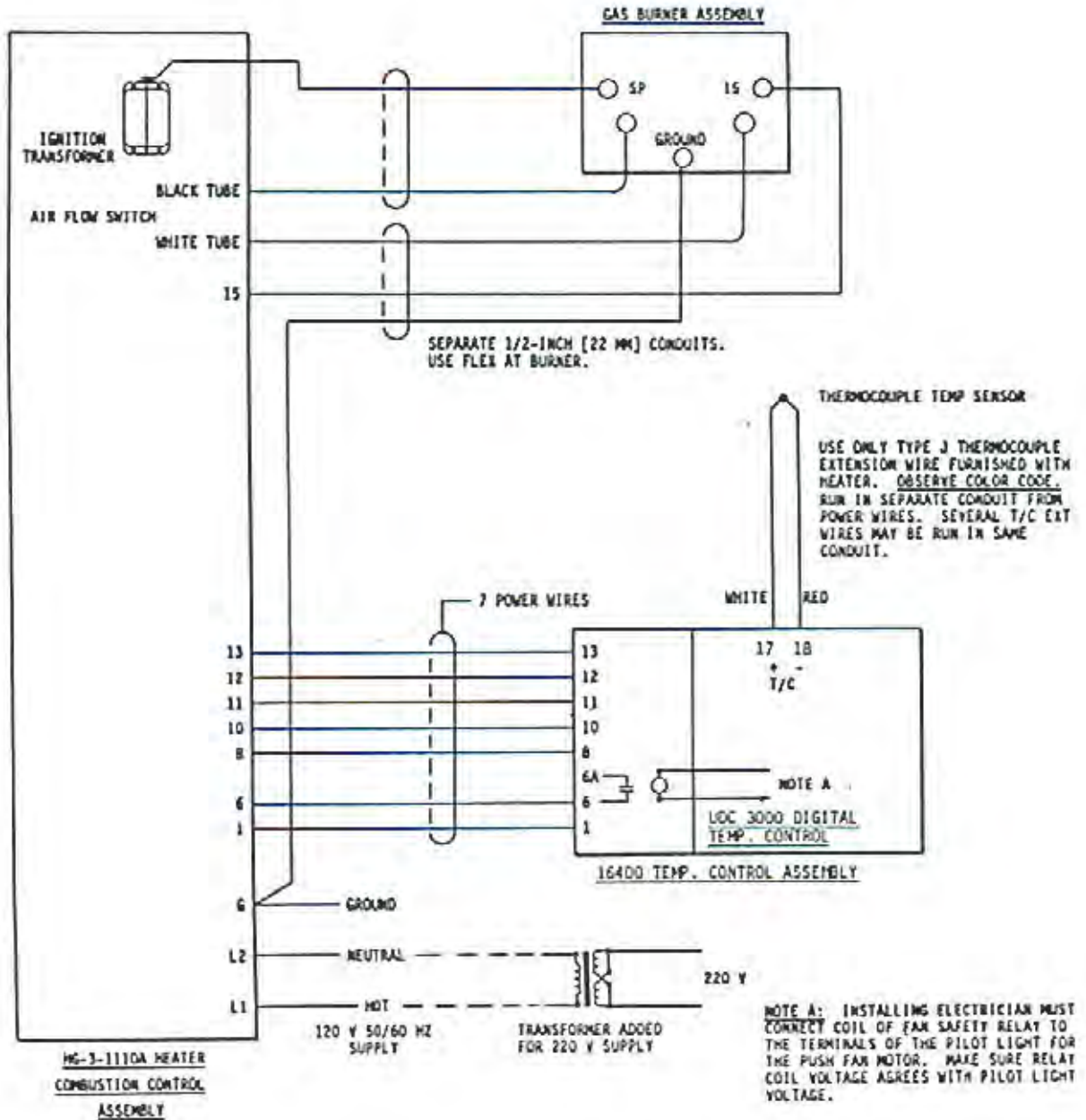

EXTERNAL ELECTRICAL CONNECTIONS

HG-3-1110A

3 MBTU/HR GAS-FIRED HEATER

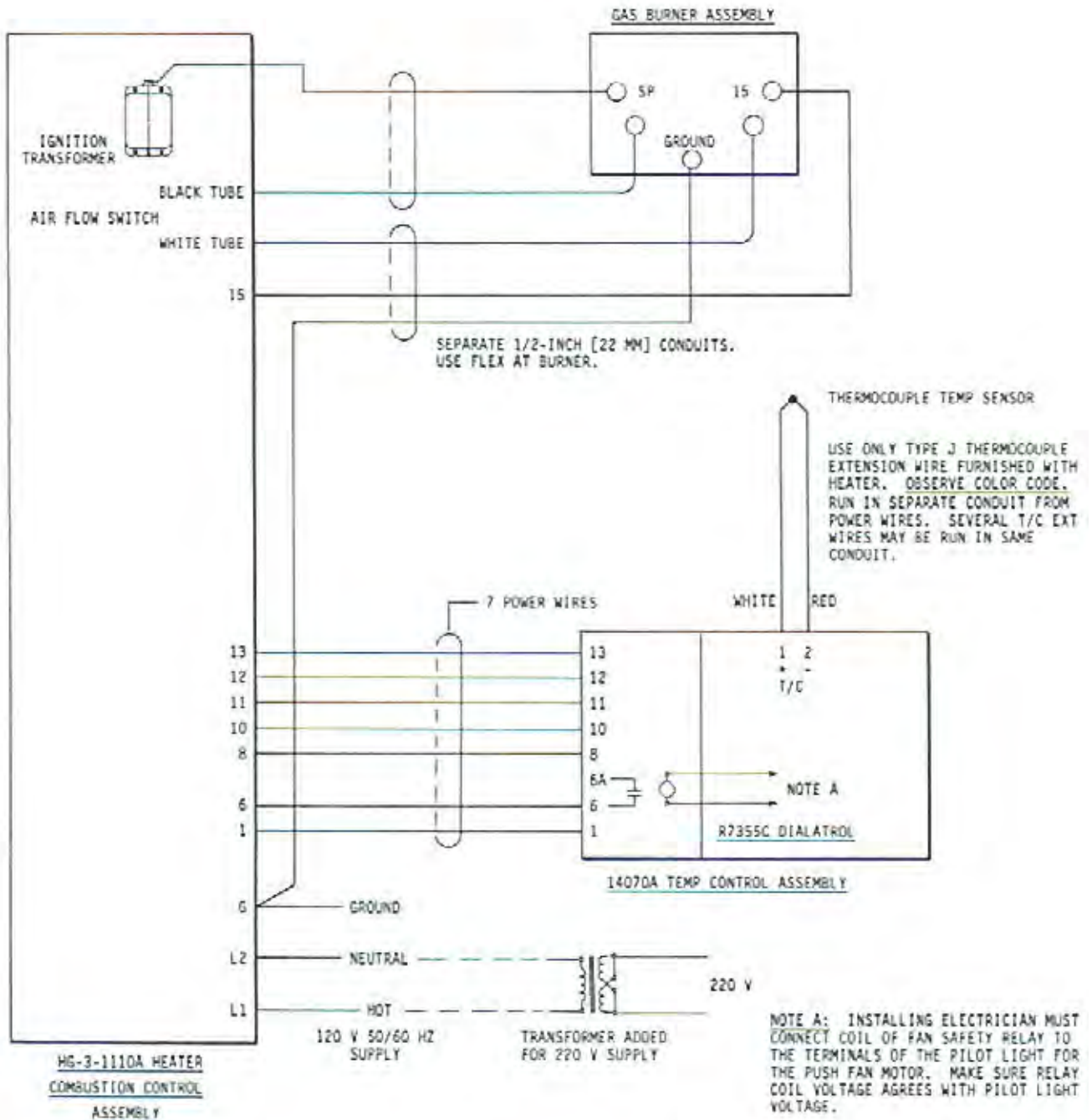

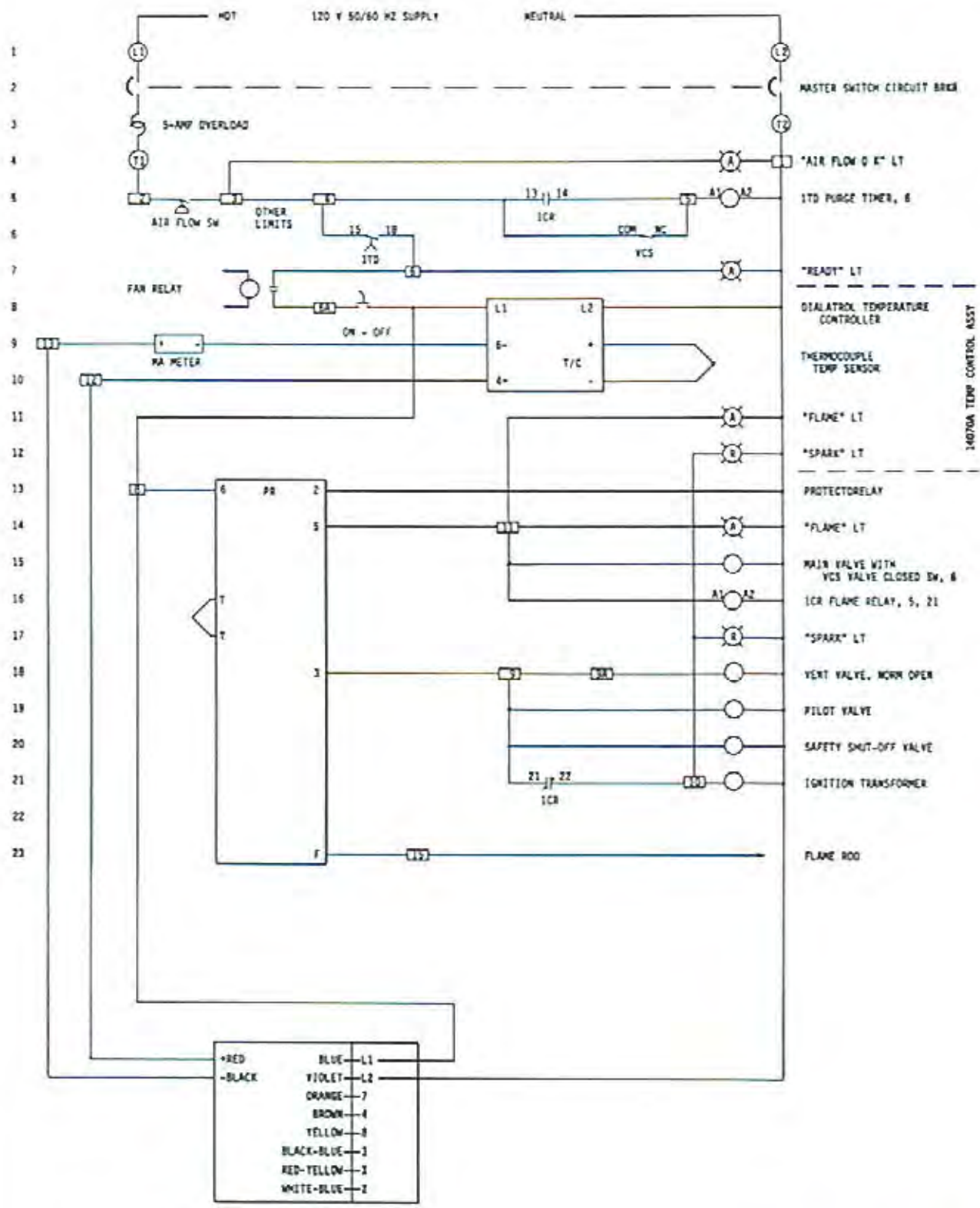

+RED	BLUE	L1
-BLACK	VIOLET	L2
	ORANGE	7
	BROWN	4
	YELLOW	8
	BLACK-BLUE	3
	RED-YELLOW	5
	WHITE-BLUE	2

BARBER-COLMAN MODULATING MOTOR

SAMUEL JACKSON MFG. CORP.		
ELECTRICAL SCHEMATIC		
HG-3-1110A		
3 MBTU GAS-FIRED HEATER		
Drawn By	SOJ	Drawing No.
DATE	4-20-65	14-2432

SAFETY FEATURES

G A S - F I R E D

SAMUEL JACKSON COTTON GIN HEATERS

Many of the safety features designed into cotton drying heaters can be tampered with and circumvented if the operating personnel are desperate to dry cotton. An important, but hidden, safety feature in all Samuel Jackson heaters is their dependable performance. Assembly of components in the factory instead of in the field and the inspection of each installation by a factory representative helps to insure trouble-free performance. One design aspect aimed at performance, but contributing to safety, is the achievement of high flame electrode current. This prevents nuisance shut downs by the flame safeguard relay which drives operators to desperation.

Specific safety features which are not ordinarily used on cotton gin heaters will be listed below.

A purge timer requires that air be flowing through the heater and drying system for 15 seconds before ignition is attempted. This removes any hazardous gas accumulated during the shut-down period.

It is customary to use a static pressure switch to infer that air is moving through the dryer. If a choke up occurs, static pressure is still present and the burner continues to operate, usually resulting in a fire. All Samuel Jackson heaters determine air flow by using a switch which measures the difference in pressure sensed by orifices pointing upstream and downstream. When air flow is reduced, the burner is turned off.

If the operator pushes the fan motor stop button without turning off the heater, the heater will keep burning until the fans have slowed down enough for the air flow switch to turn it off. In order to give instantaneous burner shut off, and serve as a safety backup for the airflow switch, we include a fan safety relay which turns off the burner when the push fan motor starter drops out.

The people who plumb the gas piping for heaters do not always remove debris from the pipes nor purge the lines. (We include fittings to make purging easy.) To prevent any debris from jamming a gas valve in the open position or causing it to leak when closed, we use the "double block and bleed" arrangement of gas valves. This means that when the burner is turned off, gas must flow through two consecutive blocking valves before reaching the burner, and the pipe between the valves is vented outside the building by a normally open valve.

When the burner flame goes out during operation, it is customary for the flame safeguard relay to fire the sparkplug immediately in an attempt to reignite. If a repairman has installed a relay with a three-second flame response time in an effort to reduce nuisance shut downs, and if air flow has been choked sufficiently to produce an explosive mixture, the result is a serious explosion. If our burner should flame out, it will first close all gas valves. When the main gas valve closes, its internal limit switch will then start the reignition process. This purge time, together with differential pressure airflow sensing, eliminates this common cause of gin dryer explosions.

GAS PIPING

Size of pipe supplying gas to heaters and other appliances should be large enough to prevent excessive pressure losses when all of them are in use. See following Table of sizes, flows and pressure losses.

Where LPG (Liquefied Petroleum Gas, Propane, Butane) is used as the fuel, see following drawing which shows recommended practices.

Emergency shut-off valves should be provided to permit turning off the fuel in an emergency. They should be located so that they are accessible in an emergency situation.

IRI (Industrial Risk Insurers) and some state and local authorities require venting the gas regulator and normally-open vent valve. NFPA 86* states:

3-3.4.3.2 Regulators shall be vented to a safe location, where vented gas cannot re-enter the building without extreme dilution. The terminating end shall be protected against water entry and bug-screened. Vent pipe shall be of adequate size so as to not lengthen response time.

3-3.4.3.3 Vent lines from multiple regulators, where manifolded together, shall be piped in such a manner that diaphragm rupture of one will not backload the others.

3-3.4.3.4 Vents from gas pressure switches, but from no other devices, may be vented into the regulator vent lines provided that switch or regulator diaphragm failure will not backload the regulator.

*Reprinted with permission from NFPA 86-1985, Standard for Ovens and Furnaces, copyright © 1985, National Fire Protection Association, Quincy, Mass. 02269. This reprint of material is not the complete and official position of the NFPA on the referenced subject which is represented only by the standard in its entirety.

THERMOCOUPLE TEMPERATURE SENSOR INSTALLATION

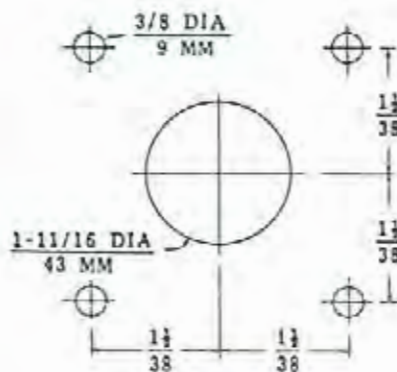
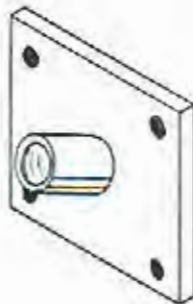
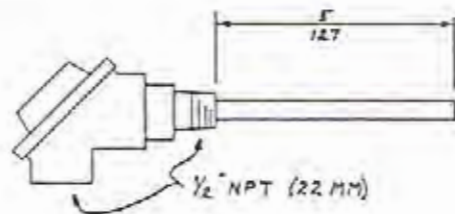
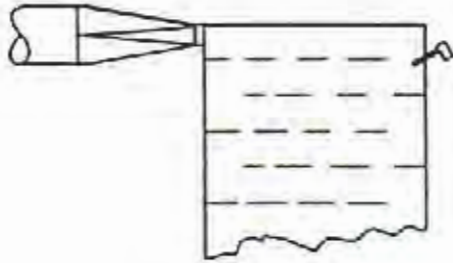

INSTALLATION HOLES
13740A SENSOR MOUNT

SENSOR LOCATION -- When used with a tower dryer, the sensor should be located, as shown, in the top shelf of the tower. This location is unusual, but it is **IMPORTANT** and **NECESSARY** for proper operation of the control. If the sensor is mounted in the lower part of the tower, heat storage in the shelves will introduce a time lag and result in on-off operation of the control.

In other drying installations, locate the sensor downstream of the point where the wet material is mixed with hot air, and where temperature changes due to material changes will be quickly sensed.

ORDER REPLACEMENT PARTS BY NUMBER:

- 13948 Thermocouple Assembly, Type J, grounded. For ordinary installations. Fast response.
- 14660 Thermocouple Assembly, Type J, ungrounded. For use where temperature set point is controlled by computer and other special situations where a grounded T/C might cause a ground loop. Slower response than 13948.
- 13740A Flanged Mount for Sensor. See mounting hole dimensions.
- 12787 Thermocouple extension wire, Type J, iron-constantan, vinyl insulation. Important: Always observe color code. Red is negative. White is positive. Specify length desired or order...
- 13949 165' [50M] of 12787

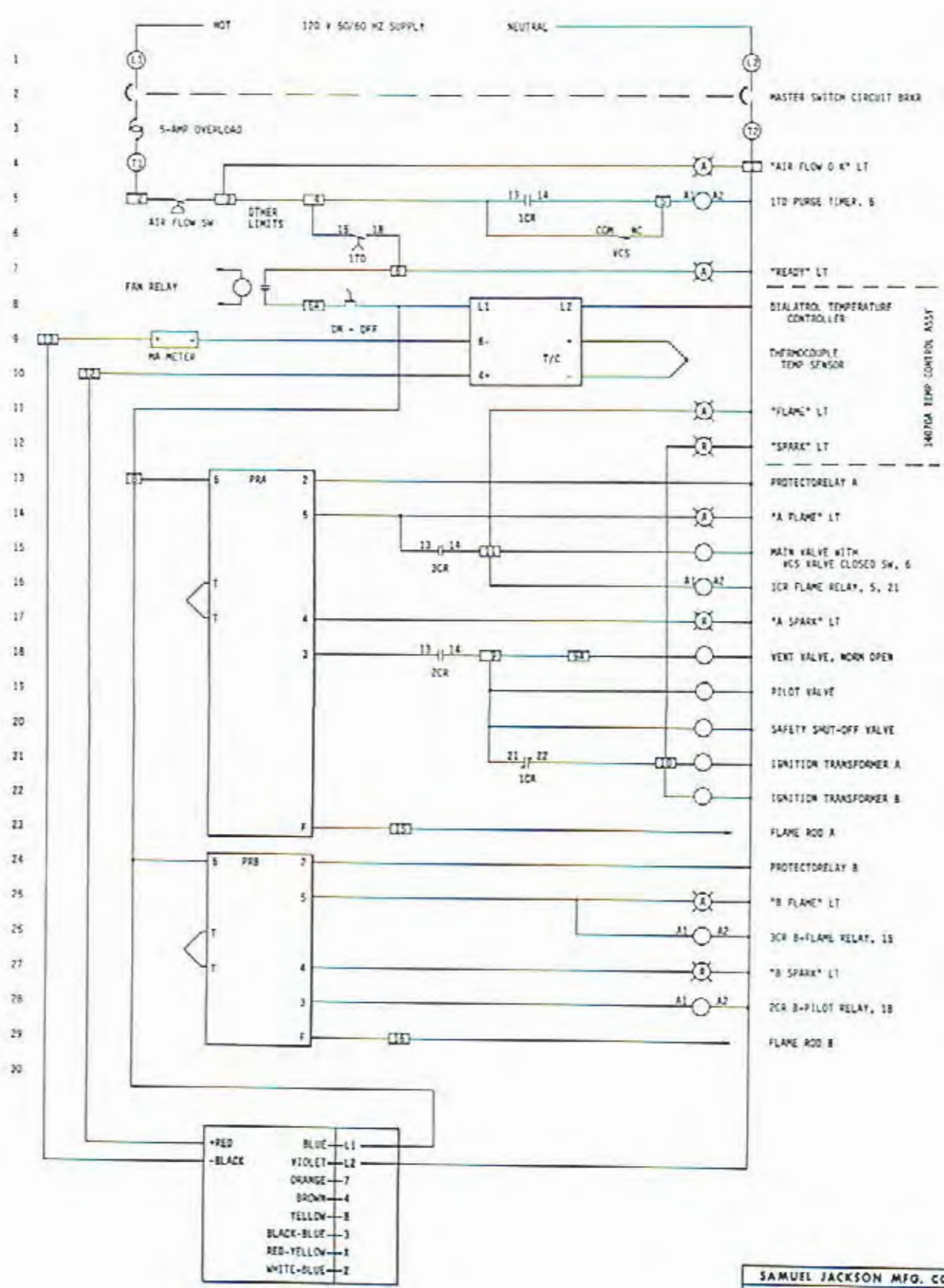

BARBER-COLMAN MODULATING MOTOR

SAMUEL JACKSON MFG. CORP.	
ELECTRICAL SCHEMATIC	
EG-6-1111A	
6 MBTU GAS-FIRED HEATER	
DATE	DRAWING NO.
6-20-85	14-2431

EXTERNAL ELECTRICAL CONNECTIONS

HG-6-1111A

6 MBTU/HR GAS-FIRED HEATER

