

STEAMROLLER 3 PANEL

3-PHASE POWER
380-415/480 VAC
50/60 HZ, 30 AMP

NOTE: RUN POWER WIRES AND SENSITIVE WIRES IN SEPARATE CONDUITS.

SUGGESTED LOCATION FOR STEAMROLLER CONTROL CABINET IS ON LOWER STEAMROLLER SUPPORT LEG.

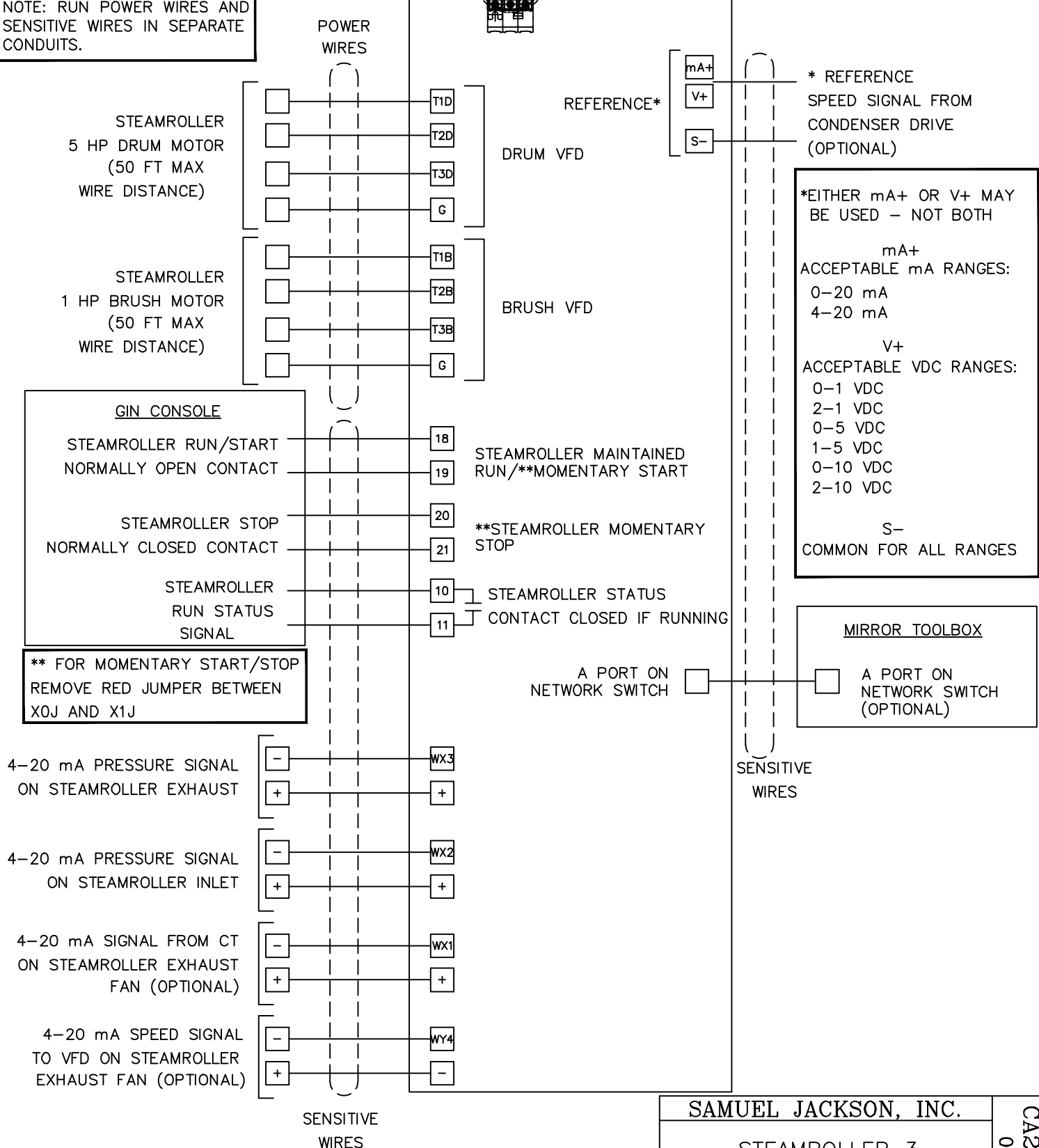

* REFERENCE SPEED SIGNAL FROM CONDENSER DRIVE (OPTIONAL)

*EITHER mA+ OR V+ MAY BE USED - NOT BOTH

mA+ ACCEPTABLE mA RANGES:
0-20 mA
4-20 mA

V+ ACCEPTABLE VDC RANGES:
0-1 VDC
2-1 VDC
0-5 VDC
1-5 VDC
0-10 VDC
2-10 VDC

S- COMMON FOR ALL RANGES

** FOR MOMENTARY START/STOP REMOVE RED JUMPER BETWEEN X0J AND X1J

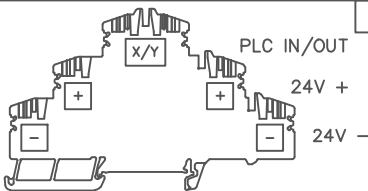
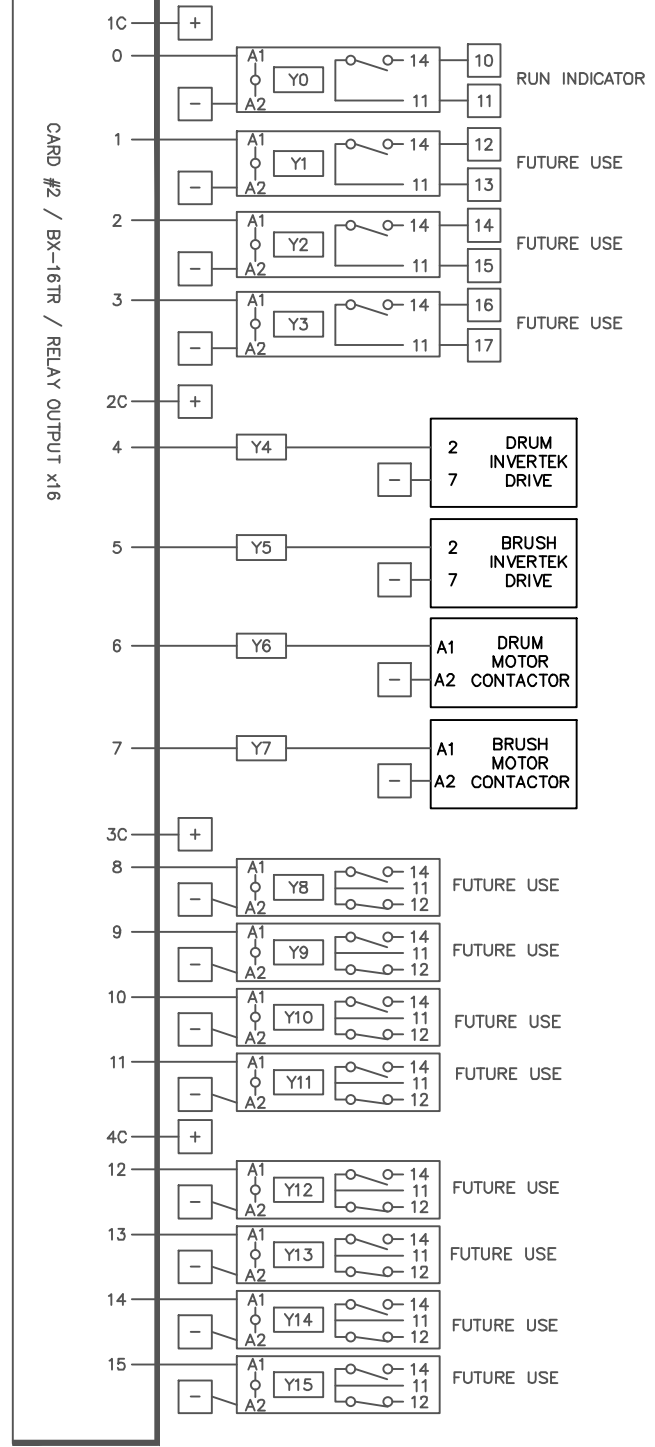
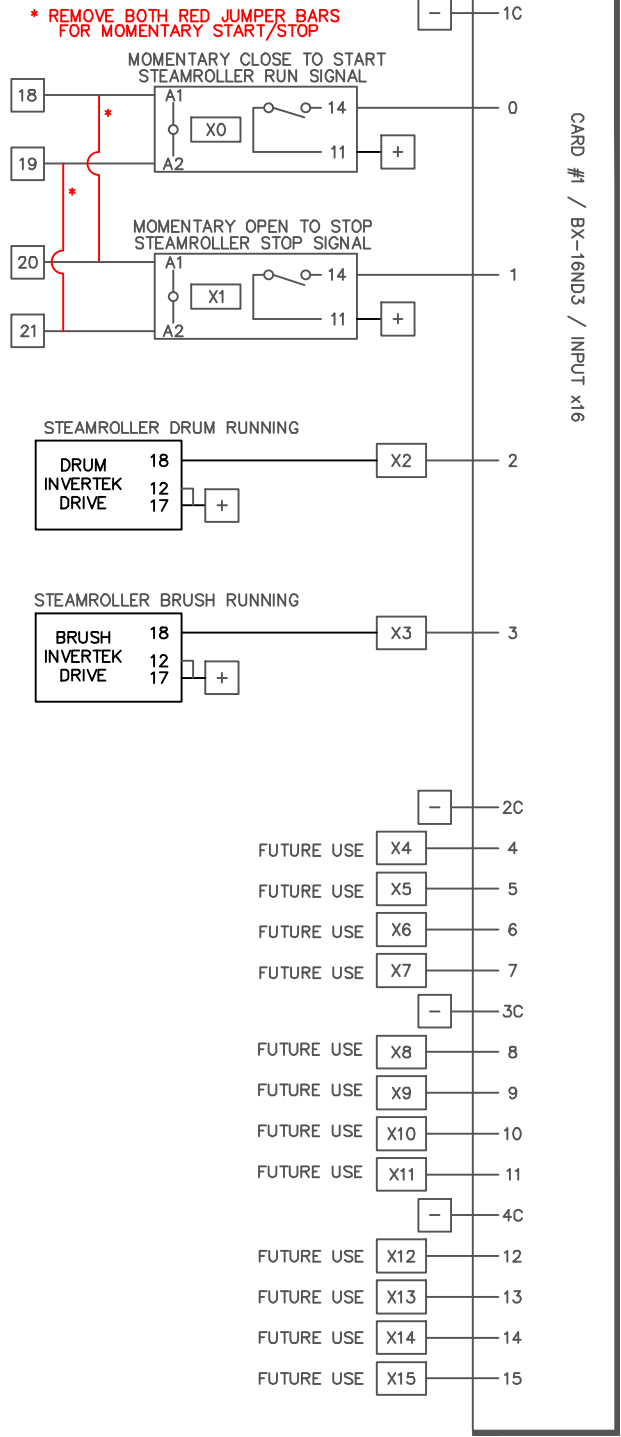
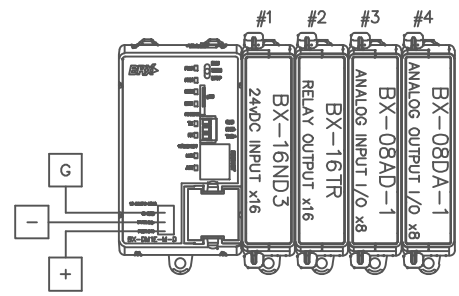
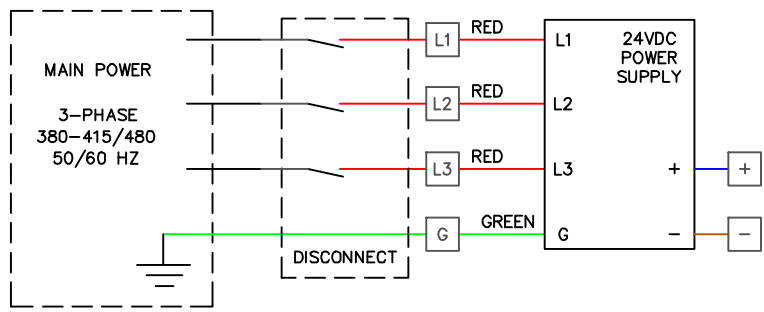

NOTES

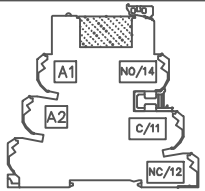

SAMUEL JACKSON, INC.
ELECTRICAL SCHEMATIC
WITH DISCRETE PLC I/O
FOR STEAMROLLER 3
CONTROL PANEL

CA20800B
04-2022

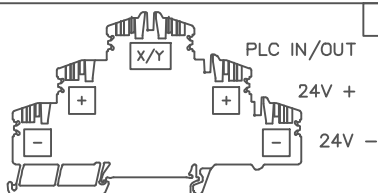
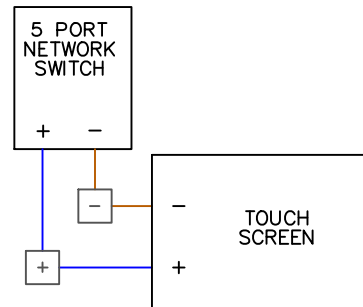
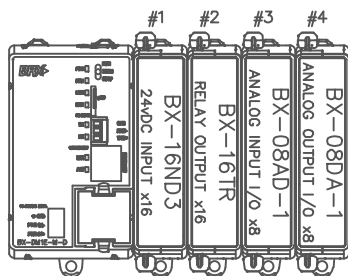
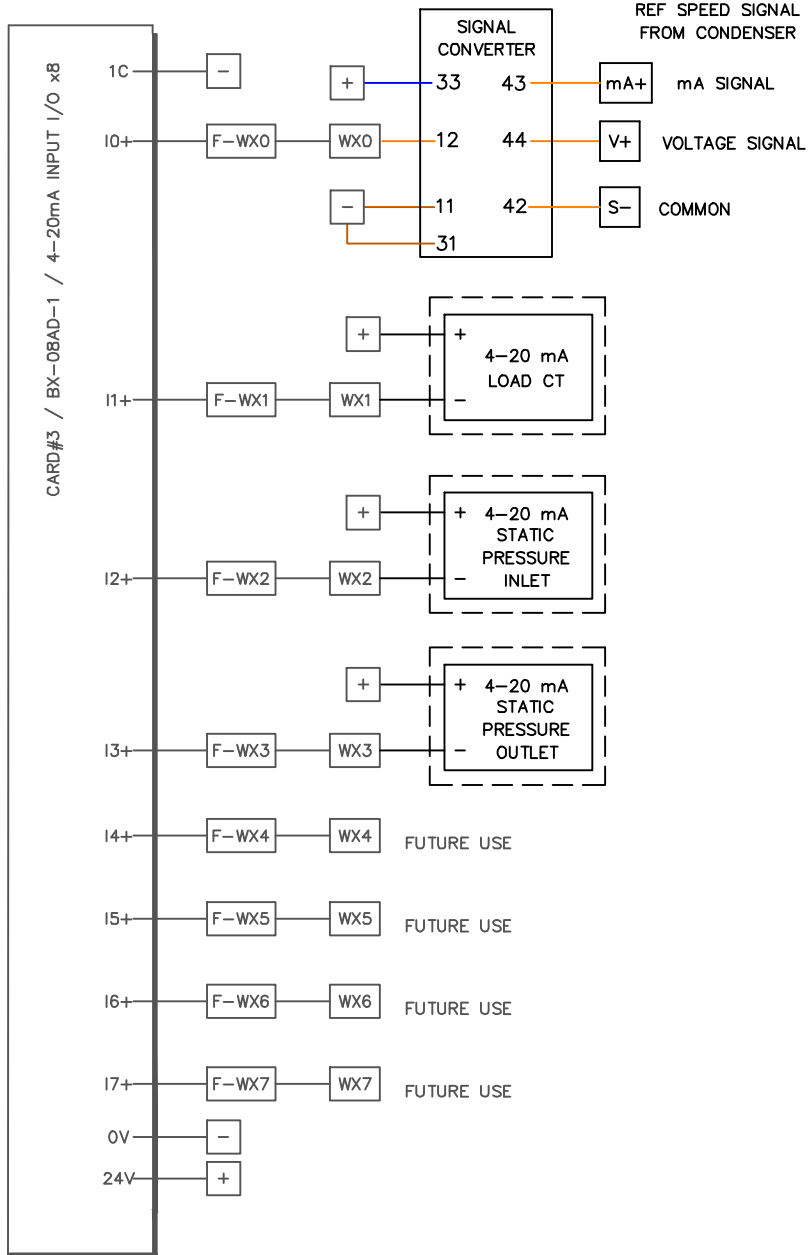
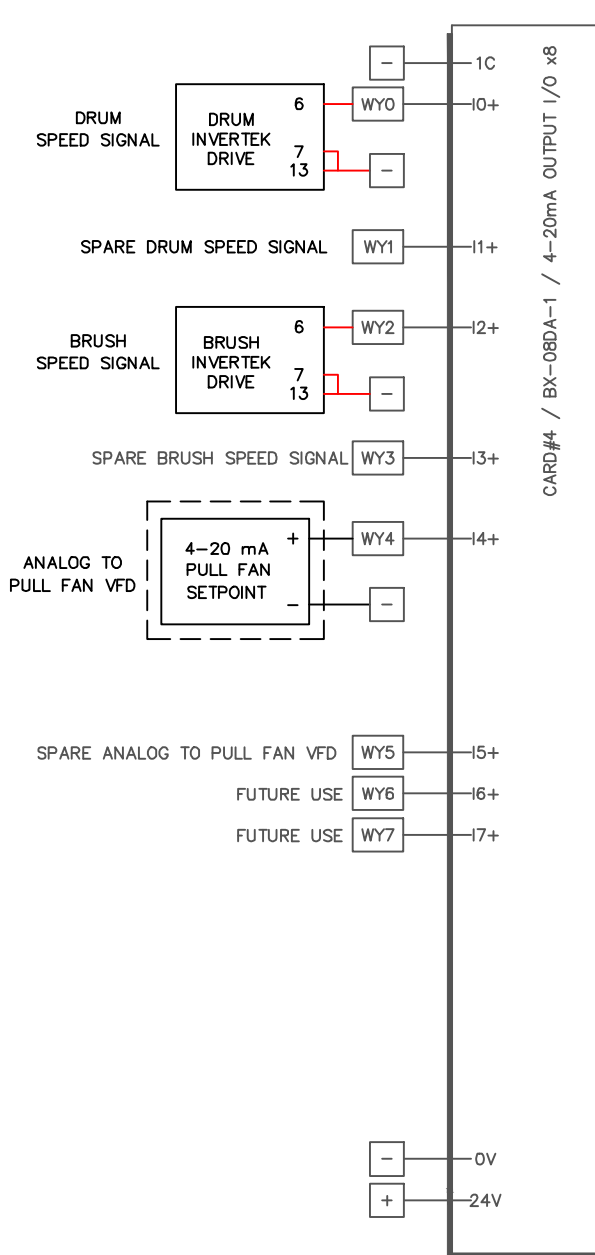

NOTES

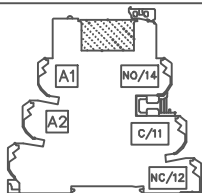

SAMUEL JACKSON, INC.
ELECTRICAL SCHEMATIC
WITH ANALOG PLC I/O
FOR STEAMROLLER 3
CONTROL PANEL

CA20801A
04-2022

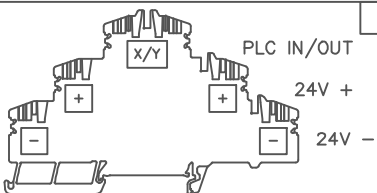
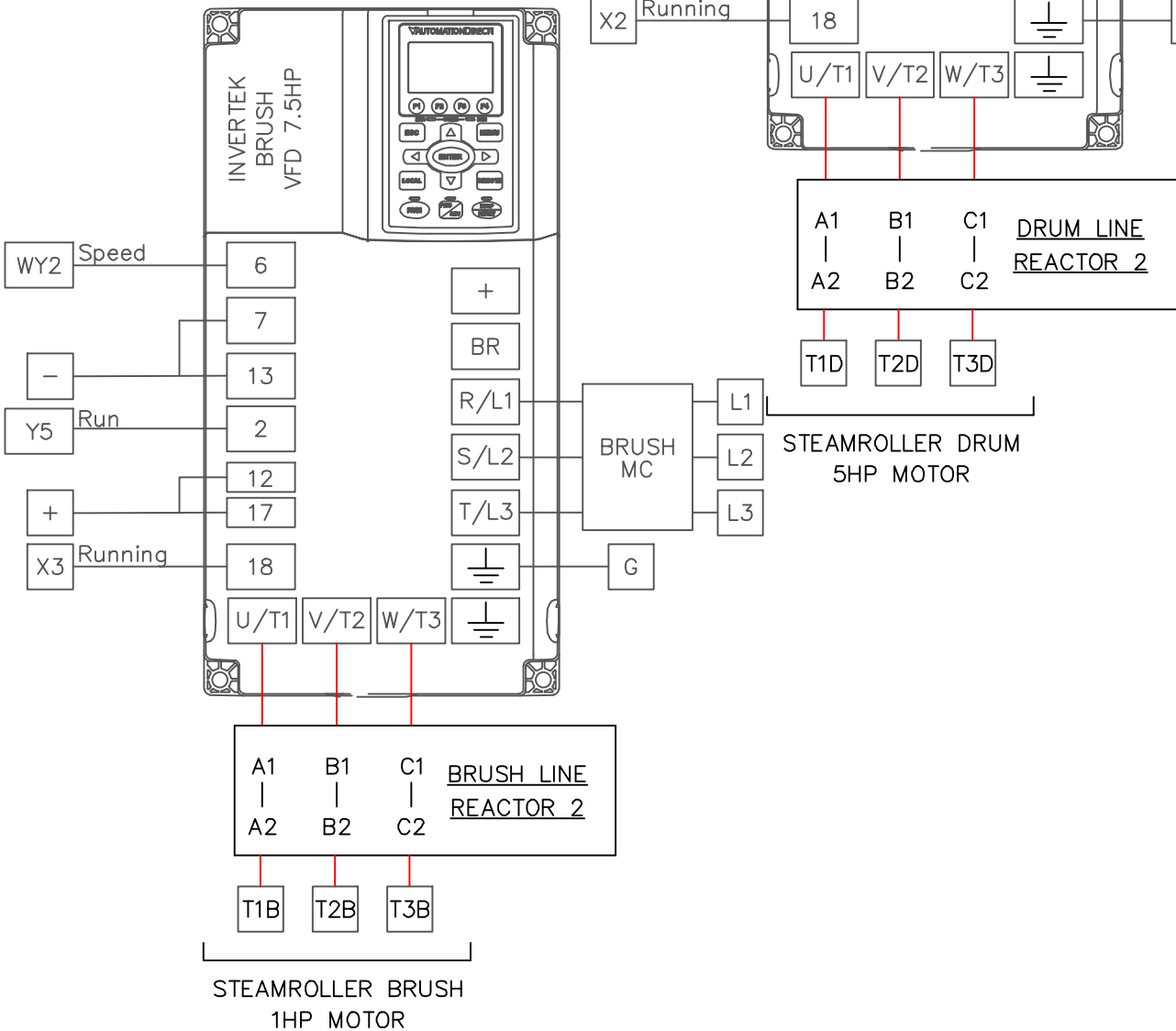
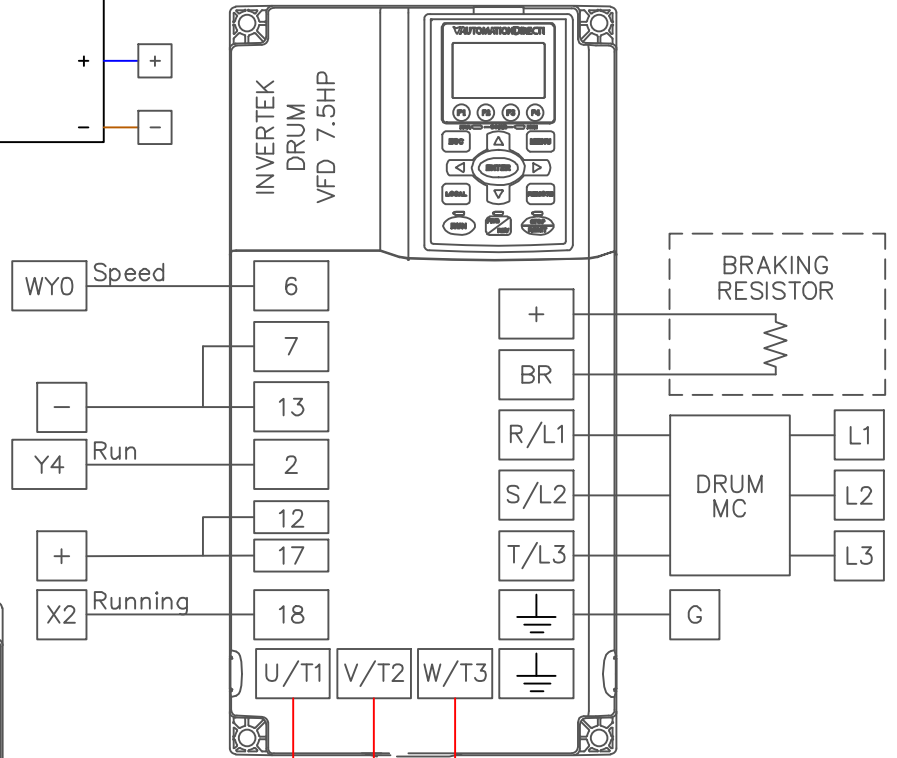
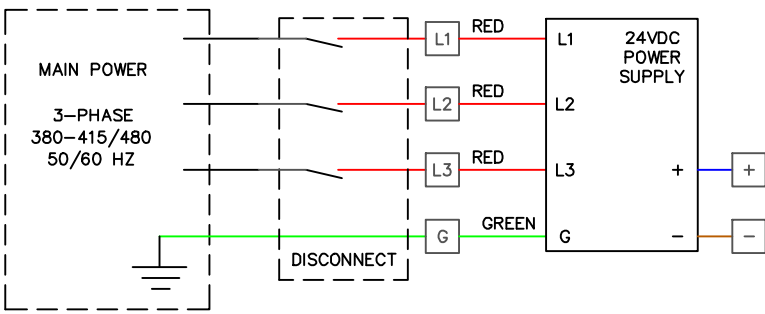

NOTES

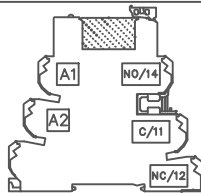

SAMUEL JACKSON, INC.

ELECTRICAL SCHEMATIC
DRUM & BRUSH VFD
FOR STEAMROLLER 3
CONTROL PANEL

CA20802B
04-2022